

4151639N(Black),4151939N(White)

Metal Daybed With Trundle

Full - Twin

Weight Limit:
Daybed: 400 Lb / 181 kg
Trundle: 250 Lb / 113 kg

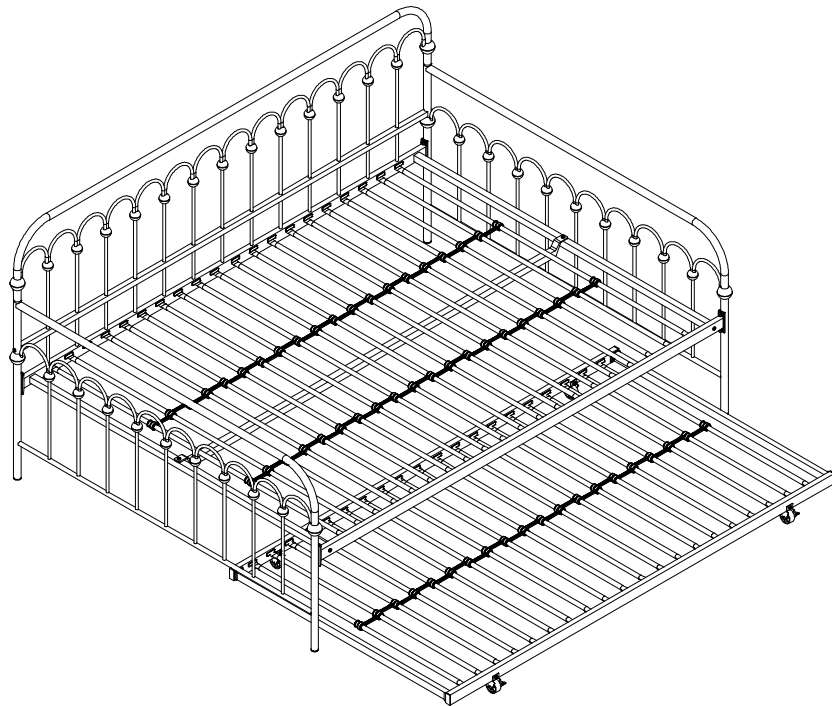

Thank you for purchasing from DHP!

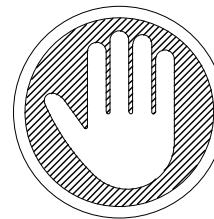

Questions, concerns, missing parts?
**CONTACT OUR CUSTOMER SERVICE DEPARTMENT
BEFORE RETURNING PRODUCT TO THE RETAILER.**

If parts are missing or damaged, we will gladly ship your replacement parts free of charge.

Visit www.dhpfurniture.com/eng/replacement-parts
or call Toll-Free **1-800-267-1739**.

You can also chat with us at www.dhpfurniture.com

Date of Purchase

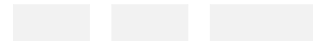

Lot Number (TAKEN FROM CARTON)

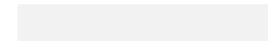

	<p>VISIT THE DHP HELP CENTER FOR ASSEMBLY VIDEOS AND MORE!</p> <p>helpcenter.dhpfurniture.com</p> <p>OR SCAN ME TO THERE ! </p>	
--	--	--

! THIS INSTRUCTION BOOKLET CONTAINS **IMPORTANT** SAFETY INFORMATION. PLEASE READ AND KEEP FOR FUTURE REFERENCE.

Limited 1 year Warranty

DHP warrants this product to be free from defects in material and workmanship and agrees to remedy any such defect. This warranty covers one year from the date of original purchase from authorized retailers. This is solely limited to the repair or replacement of defective parts and assembly labor is not included.

This warranty does not apply to any product which has been improperly assembled, subjected to misuse or abuse or which has been altered or repaired in any way. The warranty does not cover wearing, tearing, fading or splitting of the fabric (where applicable). Liability for consequential damages is excluded to the extent exclusion is permitted by law. This warranty gives you specific legal rights and you may also have other rights which vary from state to state or province to province.

To obtain warranty service, purchaser must present original bill of sale. Components repaired or replaced are warranted through the remainder of the original warranty period only. The defective components will be repaired or replaced without charge, subject to the terms and conditions described above.

The terms and conditions of the limited warranty are subject to change without notice. For the latest warranty policy, please visit www.dhpfurniture.com.

Contact Us!

For help with assembly, identifying parts, product information or to order parts, please contact us:



www.dhpfurniture.com



cs@dhpfurniture.com



1-800-267-1739

Monday to Friday 9 am to 9 pm (Eastern Time)
Saturday 10 am to 6:30 pm (Eastern Time)
Sunday 11 am to 7 pm (Eastern Time)



DHP Consumer Services
12345 Albert Hudon, Suite 100,
Montreal, Quebec H1G 3L1

Read Before Beginning Assembly

- Work in a spacious area and near where the unit will be used, preferably on a carpet, or use a piece of the cardboard packaging to protect your floor and product.
- Make sure all parts are included. Most parts are labeled or stamped on the raw edge.
- Read each step carefully. It is very important that each step of the instructions is performed in the correct order. If these steps are not followed in sequence, assembly difficulties will occur.
- This product may contain small components. Please ensure that they are kept away from small children.
- This product is designed for home use and is not intended for commercial use.

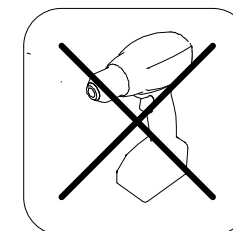
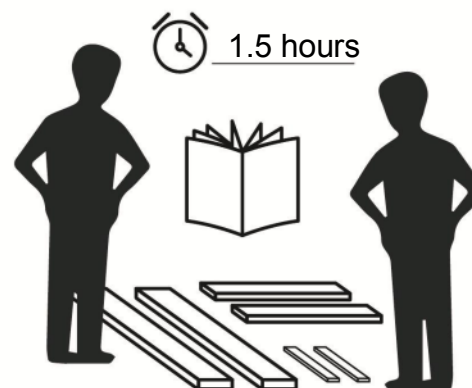

Do NOT use
powertools

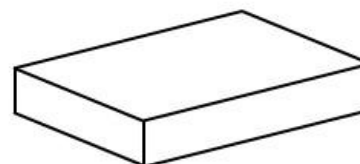

This product is shipped in
1 carton

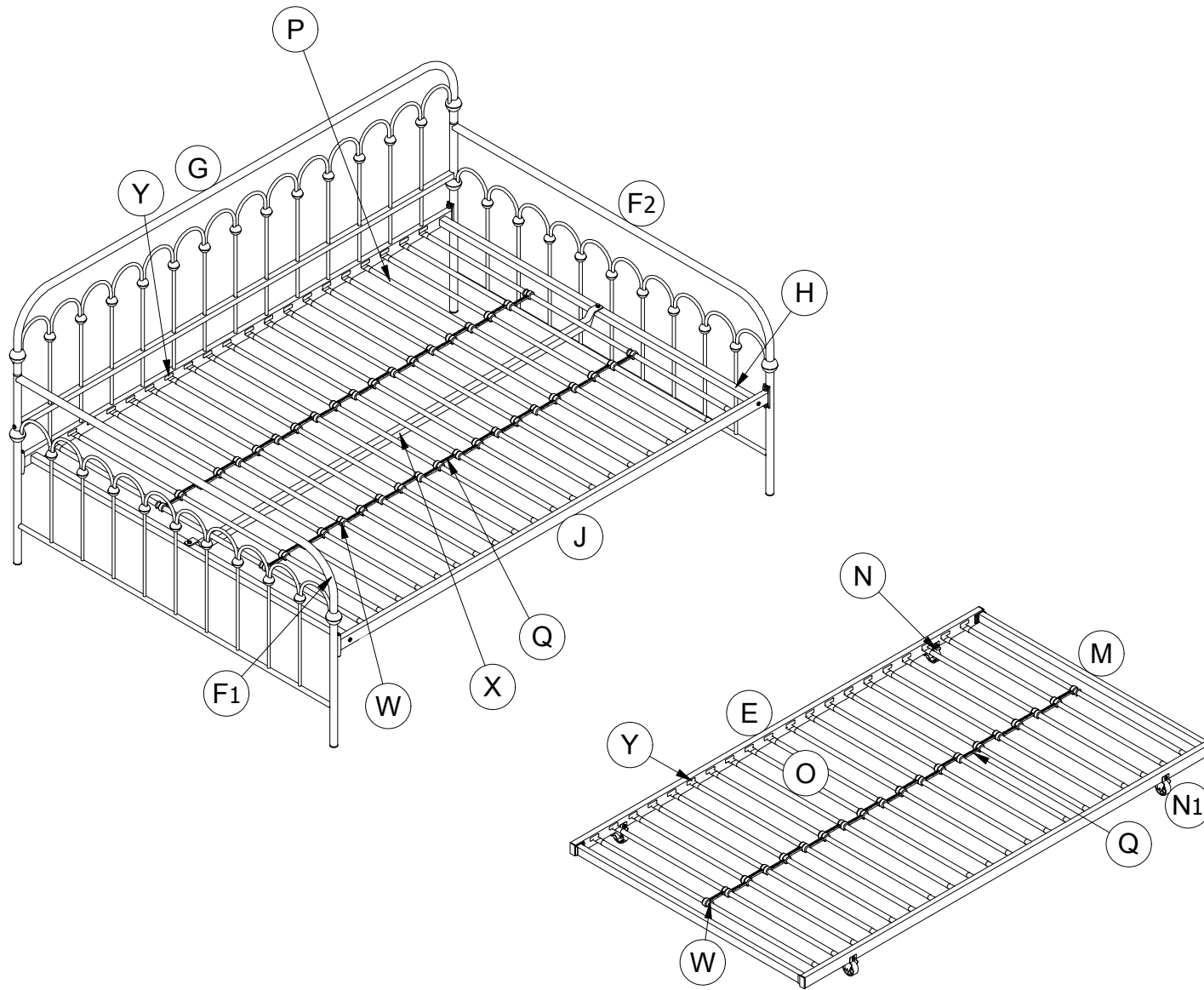

PARTS LIST



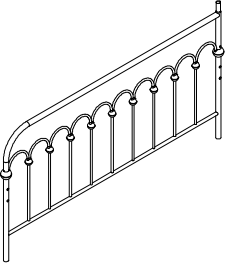
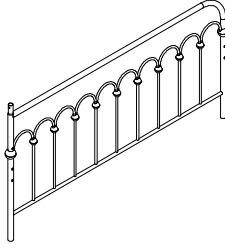
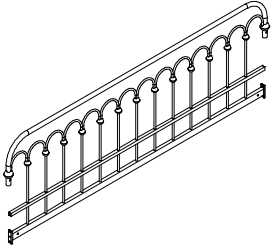
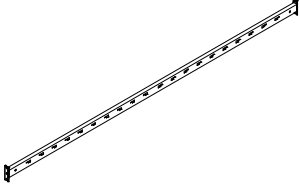
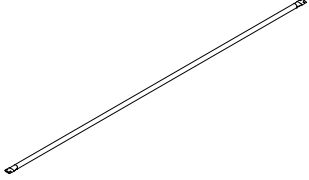
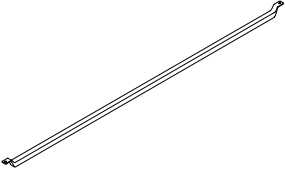
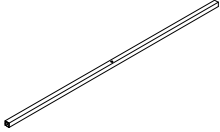

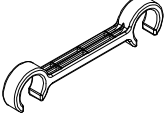
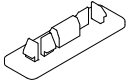
PARTS LIST

				
<p>F1 End Guard Rail 1 PC</p>	<p>F2 End Guard Rail 1 PC</p>	<p>G Rear Guard Rail 1 PC</p>	<p>J Side Rail 1 PCS</p>	<p>P Slat 20 PCS</p>
				
<p>X Center Brace 1 PC</p>	<p>H End Brace 2 PCS</p>	<p>W Spacer 40 PCS</p>	<p>Q Spacer 38 PCS</p>	<p>Y Plug 40 PCS</p>

PART NUMBERS		
PART LABELS	4151639N (Black)	4151939N (White)
F1	T1021980	T1022020
F2	T1021990	T1022030
G	T1022000	T1022040
J	T1022010	T1022050
P	T919610	T930230
X	T953960	T953940
H	T958740	T916440
W	T919480	T919480
Q	T919490	T919490
Y	T392590	T392590

IMPORTANT:

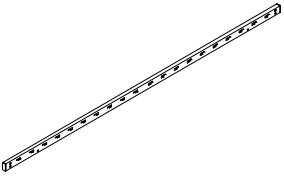
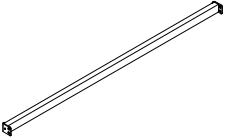
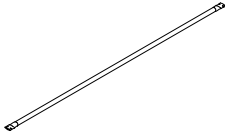
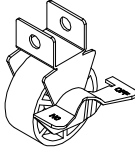
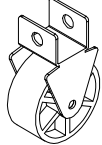
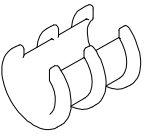
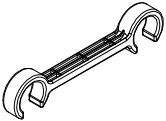
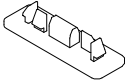

-  Each part has a unique part number. Please reference the appropriate part number when contacting customer service for replacement parts.
-  Before throwing any packaging, please verify all contents and make sure you have received all the parts listed above!

PARTS LIST







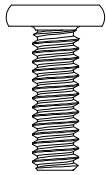

				
E Side Rail 2 PCS	M End Rail 2 PCS	O Slats 20 PCS	N1 Locking Caster 2 PCS	N Caster 2 PCS
				
W Spacer 20 PCS	Q Spacer 19 PCS	Y Plug 40 PCS		

PART NUMBERS		
PART LABELS	4151639N (Black)	4151939N (White)
E	T949290	T951650
M	T910390	T926110
O	T919600	T930130
N1	T949300	T949270
N	T949310	T949280
W	T919480	T919480
Q	T919490	T919490
Y	T392590	T392590

IMPORTANT:

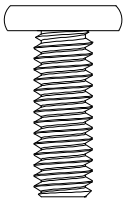
-  Each part has a unique part number. Please reference the appropriate part number when contacting customer service for replacement parts.
-  Before throwing any packaging, please verify all contents and make sure you have received all the parts listed above!

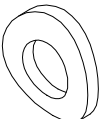
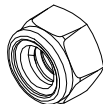
HARDWARE LIST-DAYBED

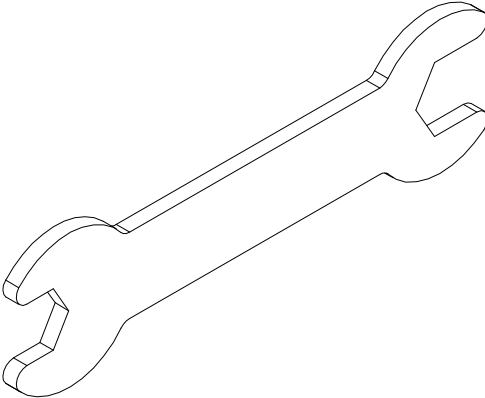
1  1/4" X 3/4" Bolt 2 PCS	2  1/4" X 1 3/4" Bolt 2 PCS	3  1/4" X 1 9/16" Bolt 4 PCS	4  1/4" X 1 7/16" Bolt 2 PCS	5  5/16" X 7/8" Bolt 8 PCS
6  5/16" Spring Washer 8 PCS	7  5/16" Curved Washer 8 PCS	8  1/4" Nut 2 PCS	9  4mm L-Allen Key 1 PC	10  Wrench 1 PC



Hardware Pack Daybed

4151639N(Black)	<input checked="" type="checkbox"/> HP # : T4151639N-00
4151939N(White)	<input type="checkbox"/> HP # : T4151939N-00

⚠ Please do not completely tighten all the hardware, until the entire assembly is complete, unless otherwise indicated in the step-by-step instructions.

⚠ The screw(s), bolt(s) to be used at each step are shown in actual size in the lower right corner of the page.

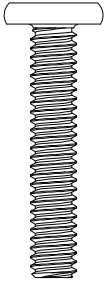
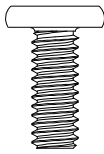
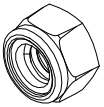
HARDWARE LIST-TRUNDLE

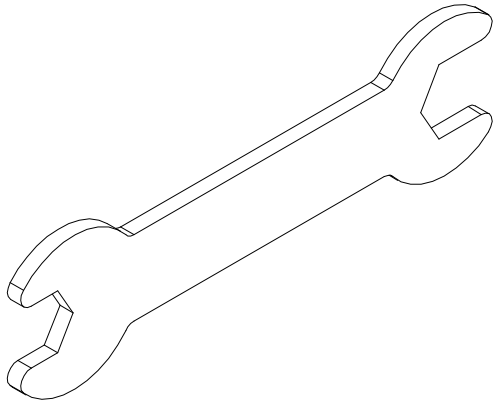
1  1/4" X 1 5/16" Bolt 4 PCS	2  1/4" X 5/8" Bolt 8 PCS	3  1/4" Nut 4 PCS
4  4mm L-Allen Key 1 PC	5  Wrench 1 PC	

Hardware Pack Trundle

4151639N(Black)	<input checked="" type="checkbox"/> HP # : T5585196-02
4151939N(White)	<input type="checkbox"/> HP # : T5585096-02

⚠ Please do not completely tighten all the hardware, until the entire assembly is complete, unless otherwise indicated in the step-by-step instructions.

⚠ The screw(s), bolt(s) to be used at each step are shown in actual size in the lower right corner of the page.

Step 1

To Protect the **Rear Guard Rail G**, we've added two extra Bars. Please remove and discard the Bars before starting the assembly.

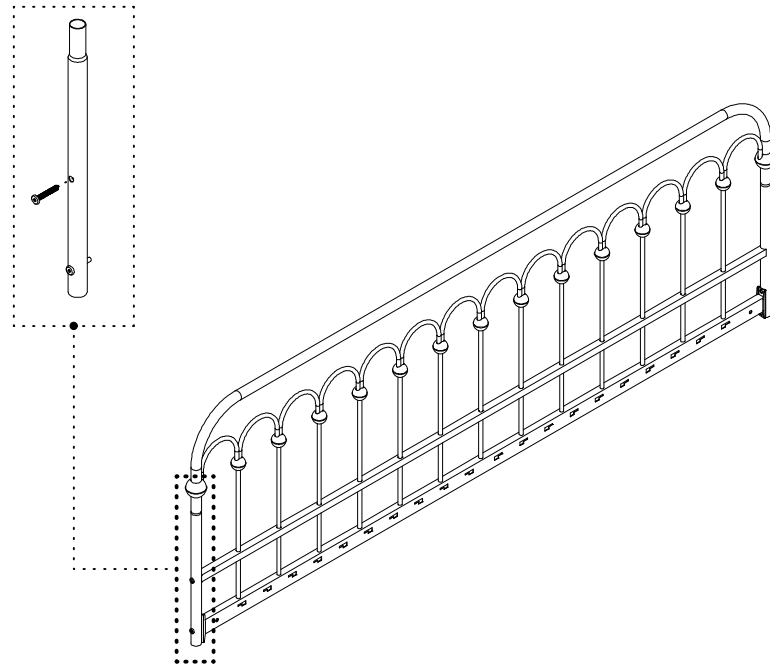

 Discard

Step 2

The following instructions will illustrate how to assemble the Daybed from **Step 2** to **Step 7**. Please use the Daybed Hardware Pack:
4151639N(Black): **T4151639N-00**.
4151939N(White): **T4151939N-00**.
Attach Side Rail **J** to End Guard Rail **F1** and End Guard Rail **F2** with bolts **5**, spring washers **6**, and curved washers **7**.

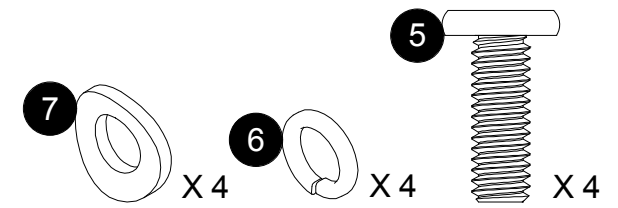
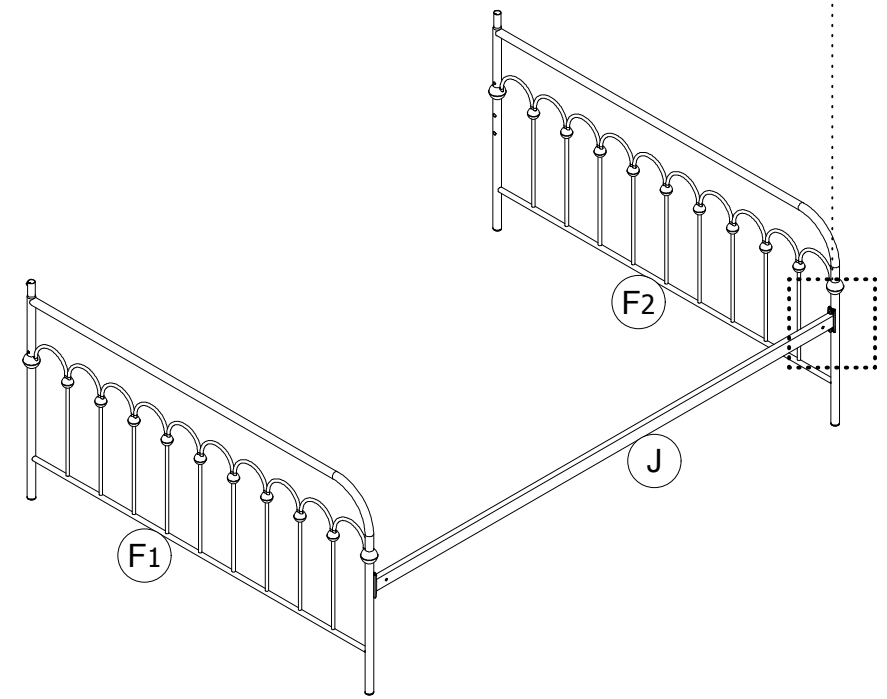
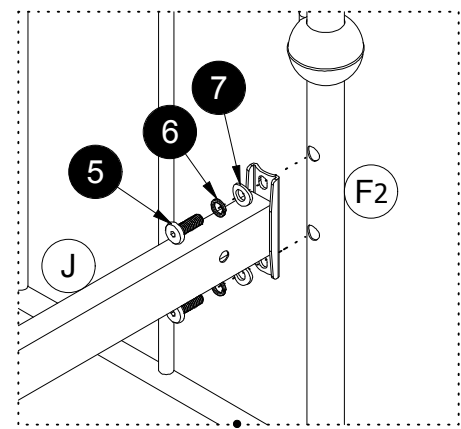
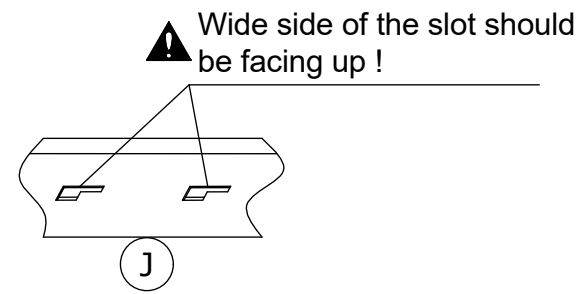

Step 3

⚠ Please strictly follow the assembly from **Step 3** to **Step 4**, or you may experience difficulty with the assembly.

3.1 Insert Rear Guard Rail **G** onto End Guard Rail **F1** and End Guard Rail **F2**.

3.2 Attached Rear Guard Rail **G** to End Guard Rail **F1** and End Guard Rail **F2** with bolts **5**, spring washers **6**, and curved washers **7**.

⚠ Do not tighten the bolts, just finger tighten the bolts to the holes.

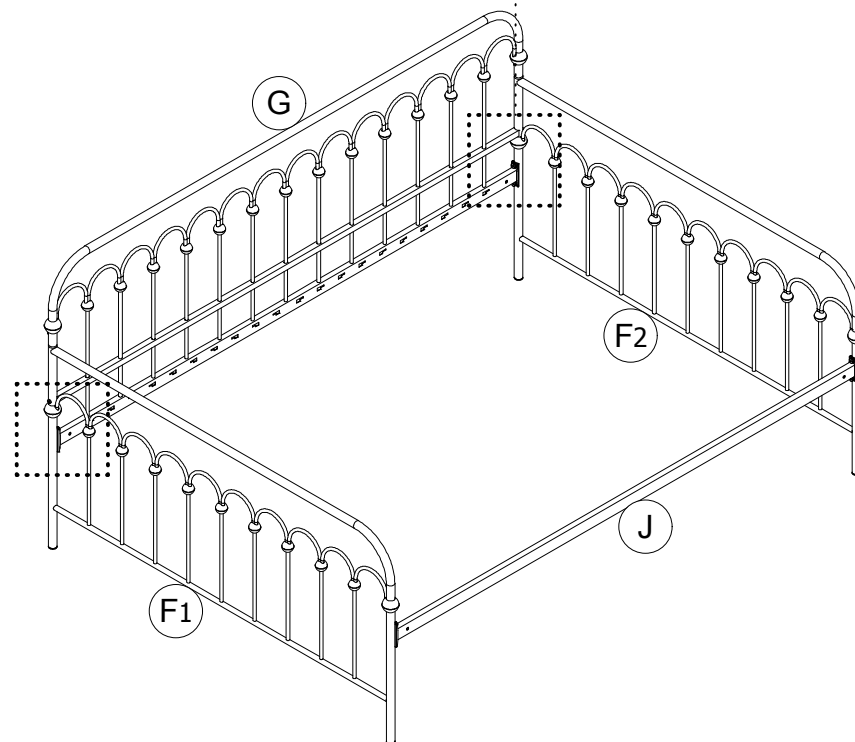
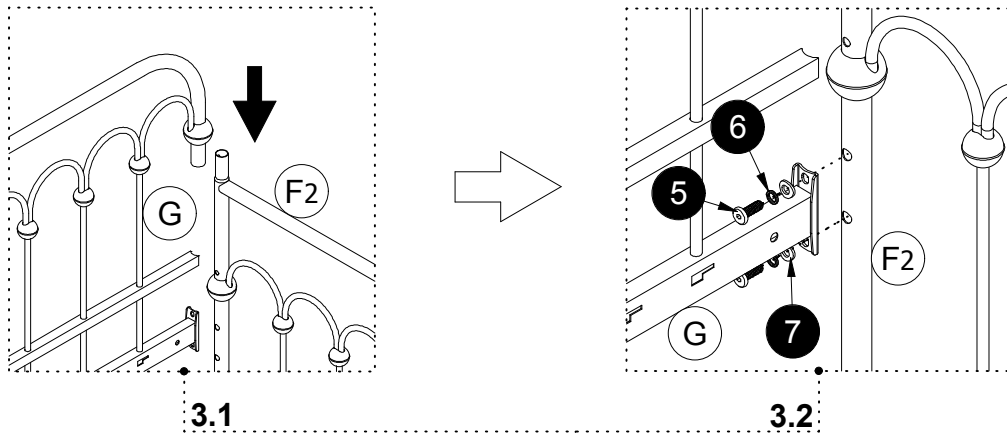

If Bolts do not align with the holes.

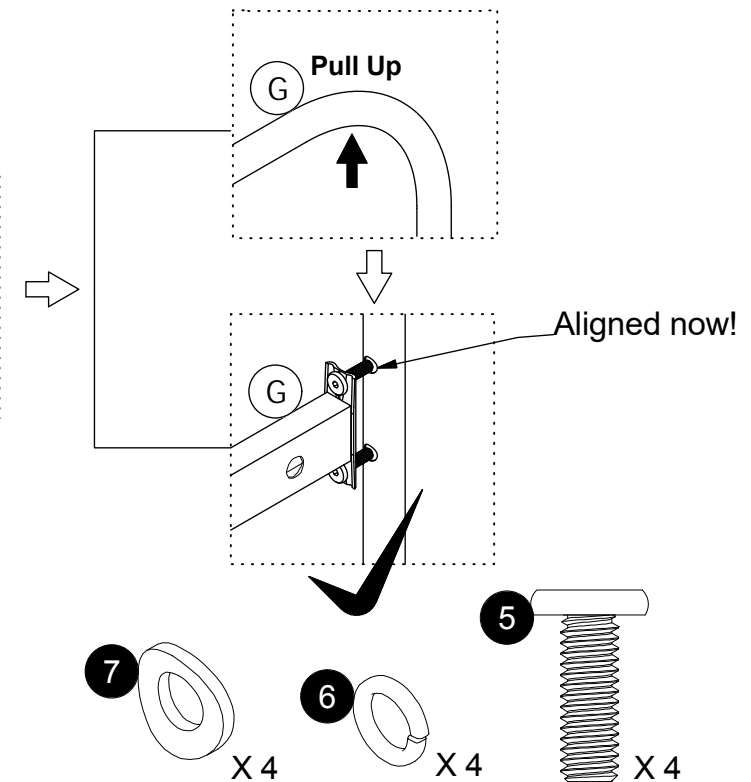
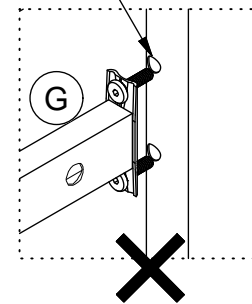

Step 4

Screw Rear Guard Rail **G** to End Guard Rail **F1** and End Guard Rail **F2** with bolts **1**.
Screw End Guard Rail **F1** and End Guard Rail **F2** to Rear Guard Rail **G** with bolts **2**.

! Make sure all bolts before this step are loose so that you can move parts to align the holes.

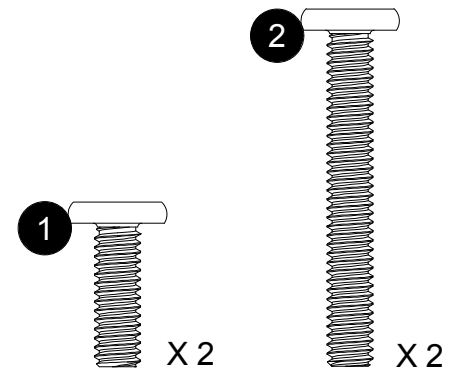
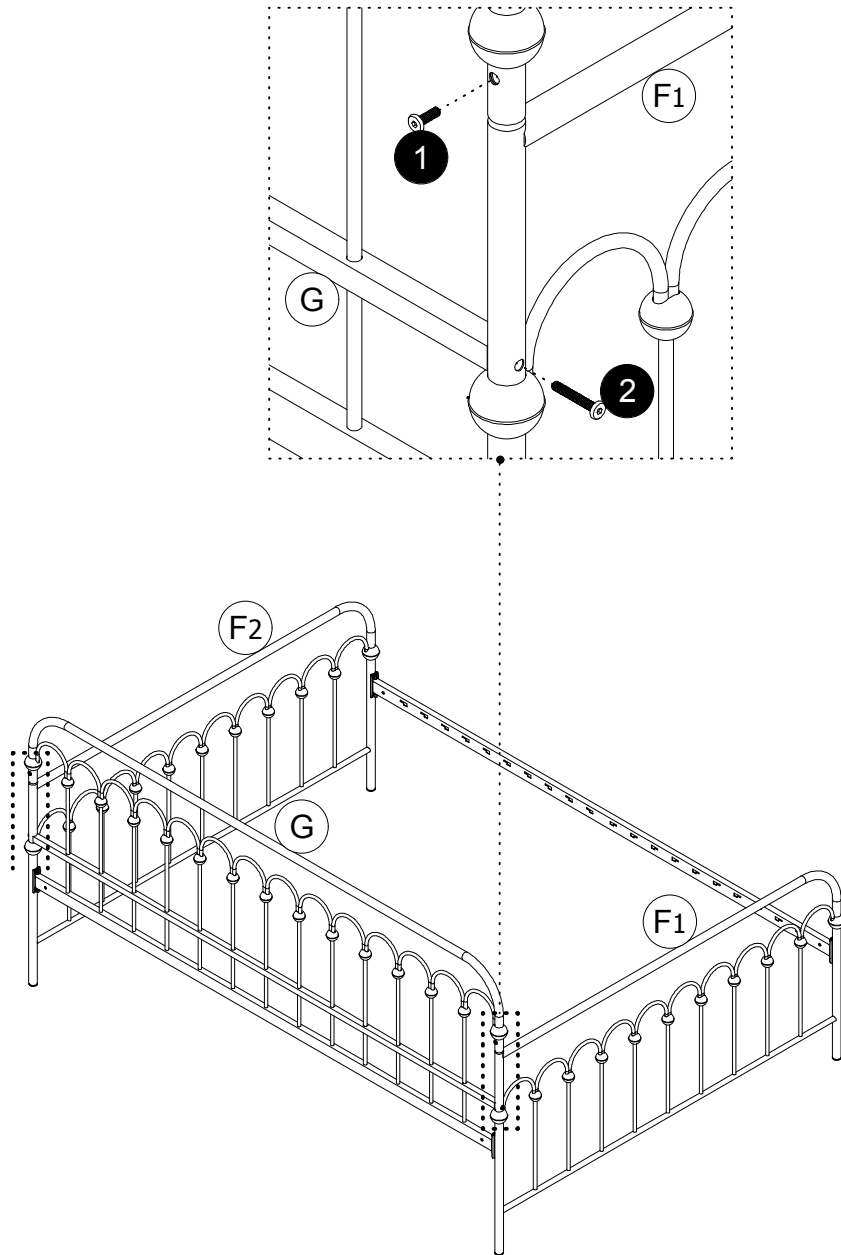

Step 5

5.1 Attach End Brace **H** X 2 to Rear Guard Rail **G** and Side Rail **J** with bolts **3**.

5.2 Attach Center Brace **X** to End Brace **H** X 2 with bolts **4** and nuts **8**.

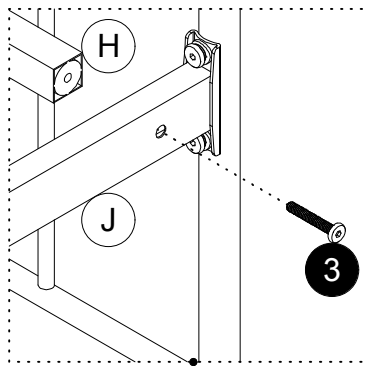

5.1

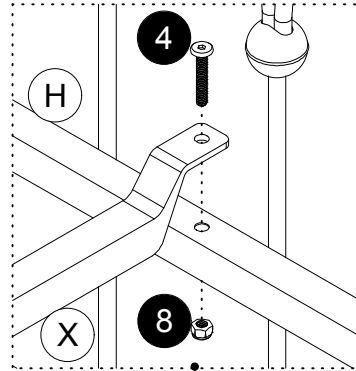

5.2

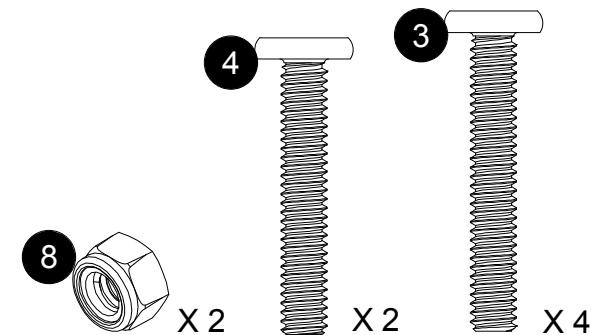
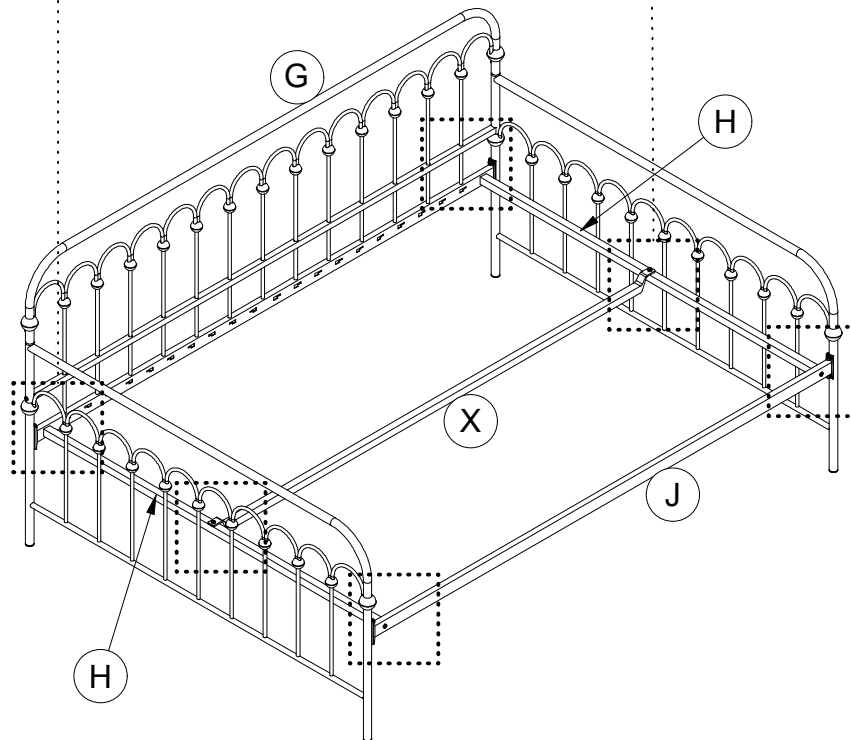

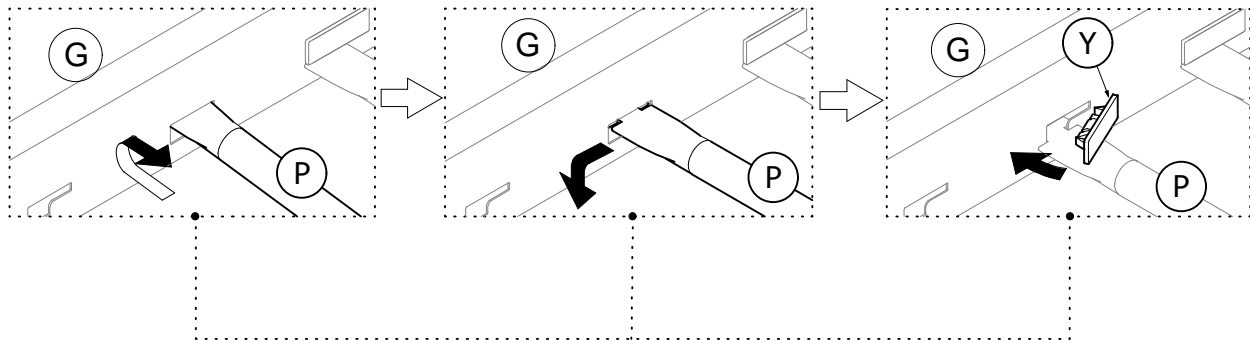

Step 6

Insert Slats **P** into Rear Guard Rail **G** and Side Rail **J** as illustrated, then lock Slats **P** into place with Plugs **Y**.

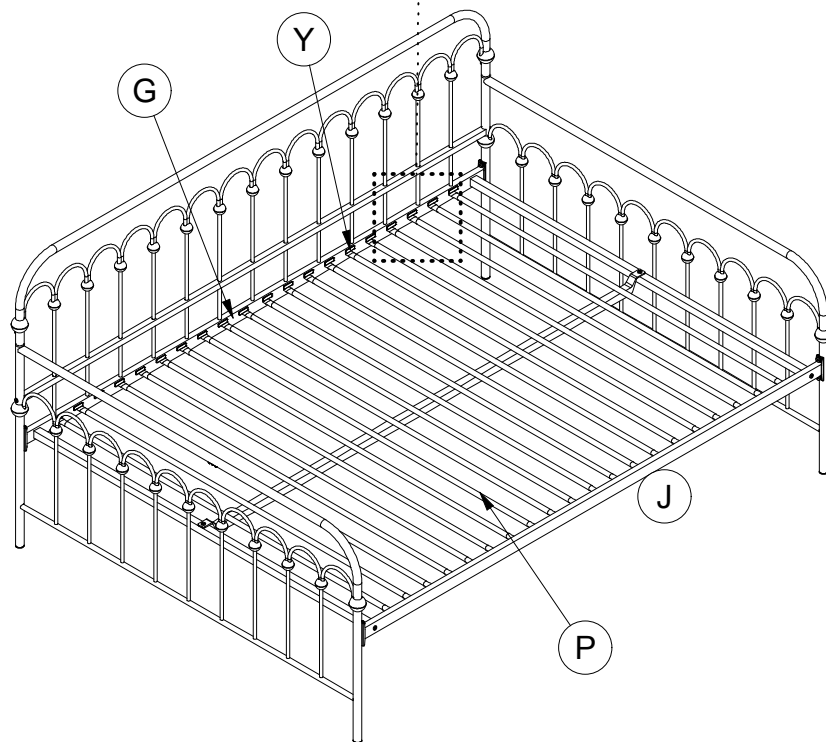

Step 7

7.1 Press Spacers **W** onto Slats **P** as illustrated.

7.2 Attach Spacers **Q** to Spacers **W** alternating left and right as illustrated.

⚠ For better performance, attach the Slat Spacers **W** & **Q** at equal spaces.
(Approximately = 17.5 inches or 445 mm for upper bed).

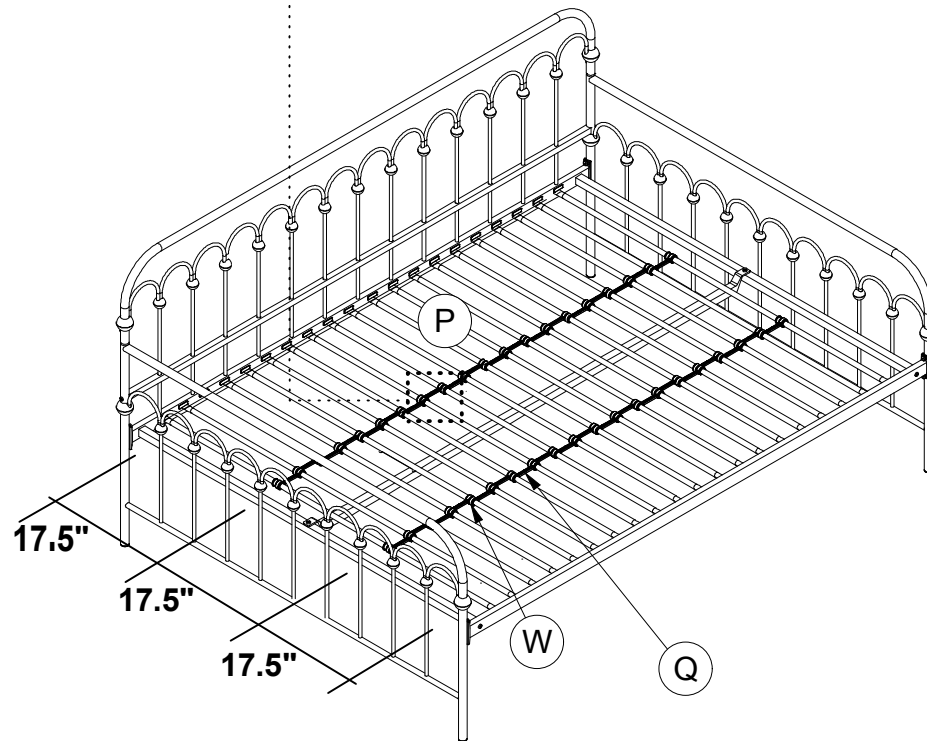
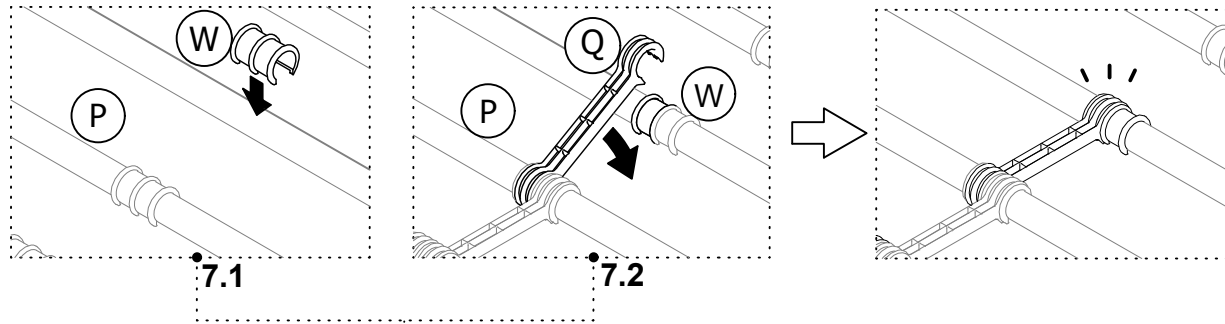

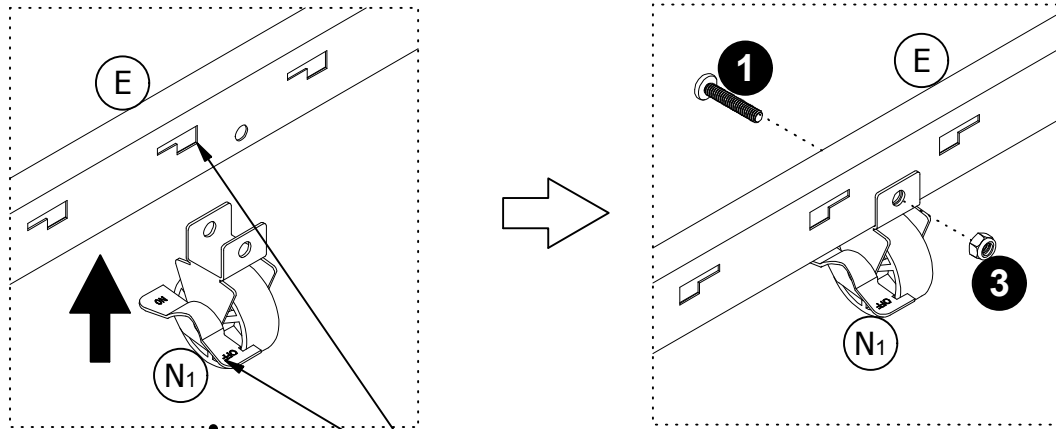

⚠ The Lever "OFF" should be oriented on the same side of slat slots.

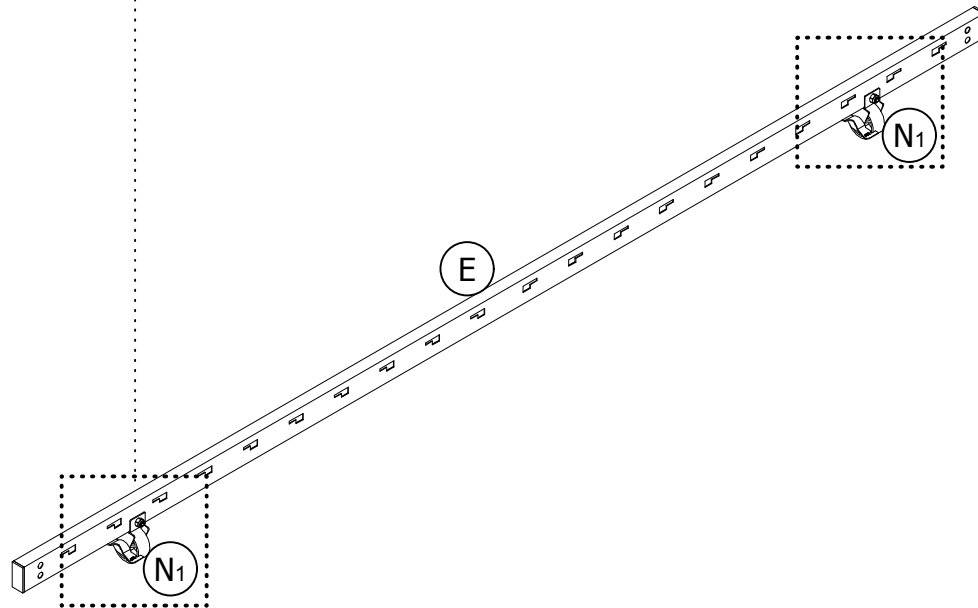

Step 8

The following instructions will illustrate how to assemble the Trundle from **STEP 8** to **STEP 12**. Please use the Trundle Hardware Pack:

4151639N (Black) : T5585196-02

4151939N (White) : T5585096-02.

Attach Locking Caster **N₁** X 2 to one Side Rail **E** with bolts **1** and nuts **3**.

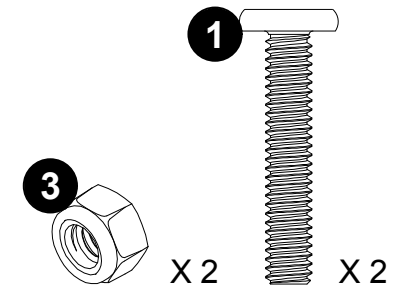

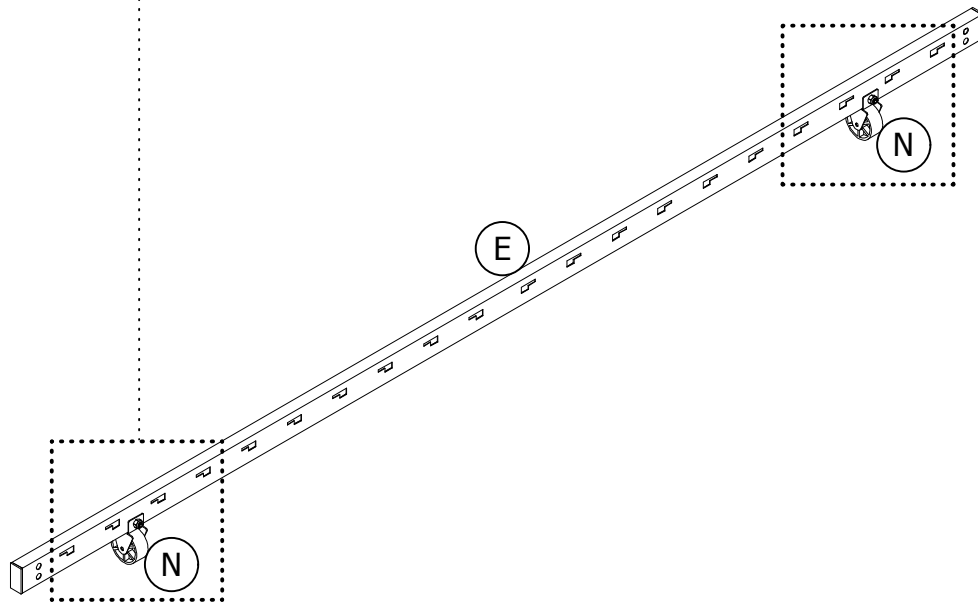
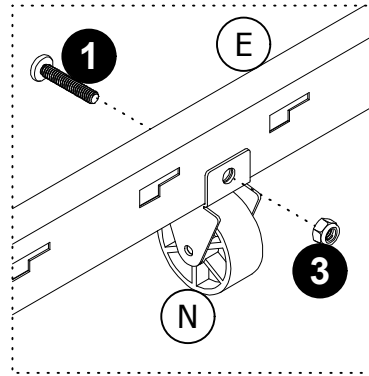
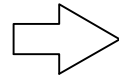
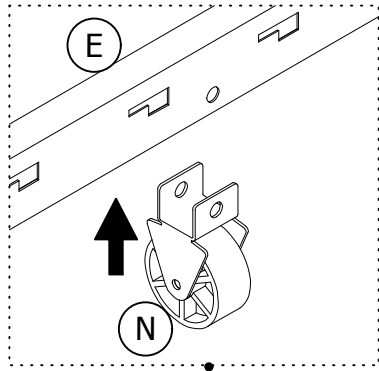

Step 9

Attach Caster **N** X 2 to the other Side Rail **E** with bolts **1** and nuts **3**.

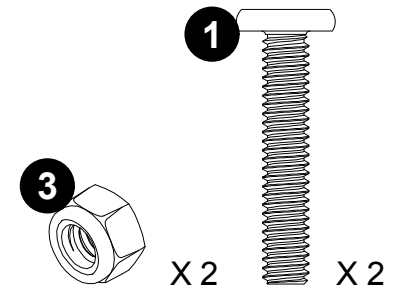

Step 10

Attach End Rail **M** X 2 to Side Rail **E** X 2 with bolts **2**.

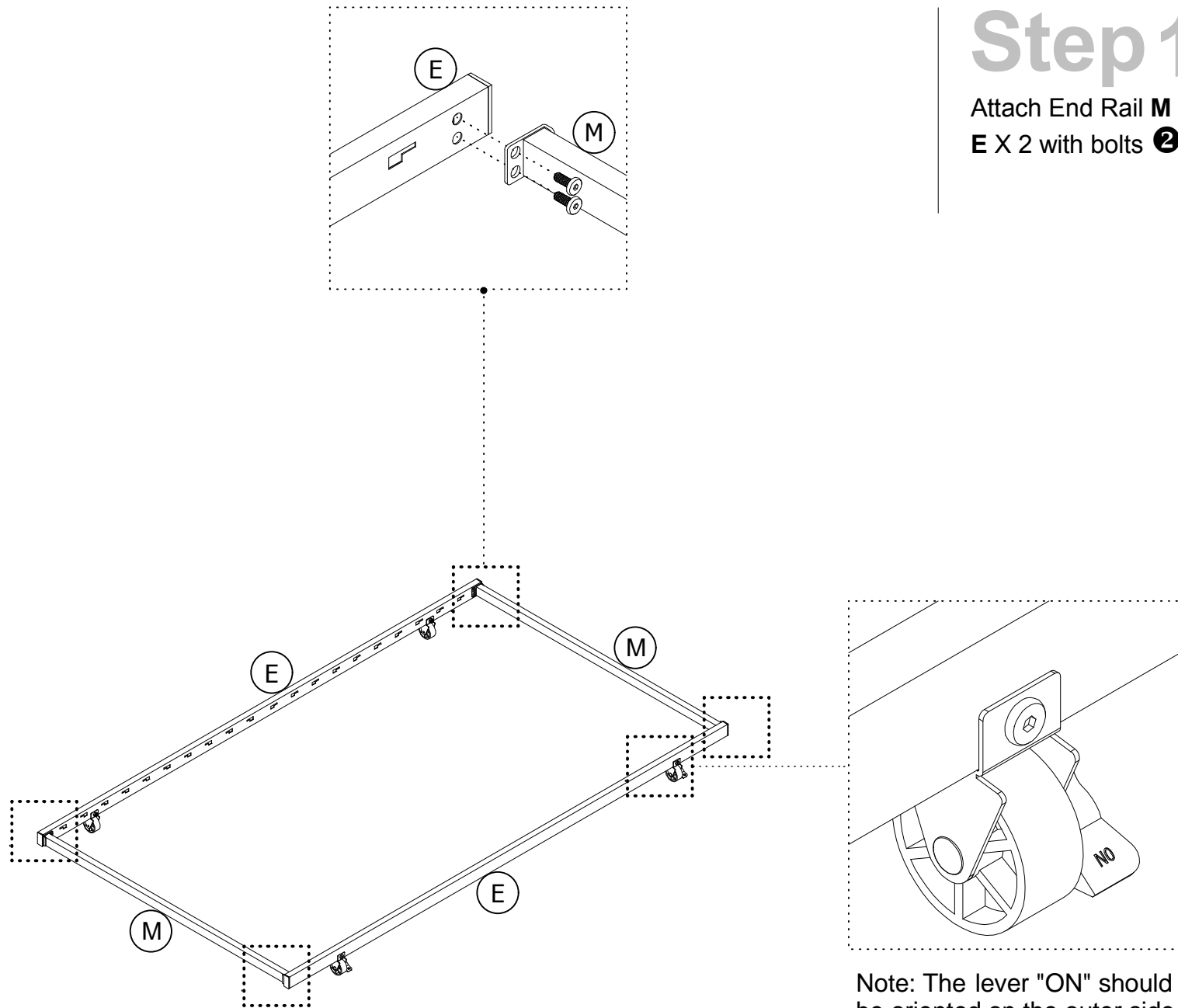

Note: The lever "ON" should be oriented on the outer side.

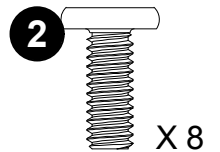

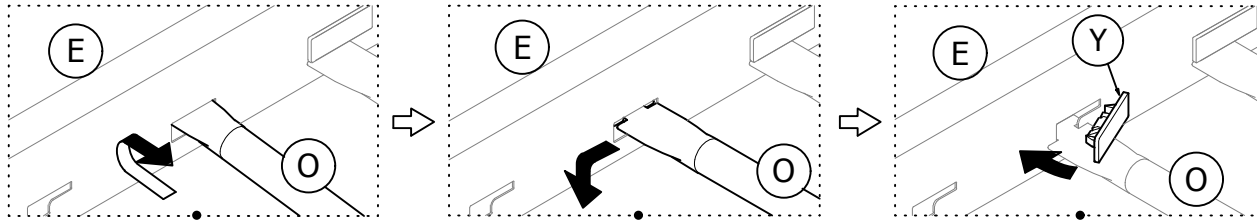

Step 11

Insert Slats **O** into Side Rail **E** X 2 as illustrated, then lock Slats **O** into place with Plugs **Y**.

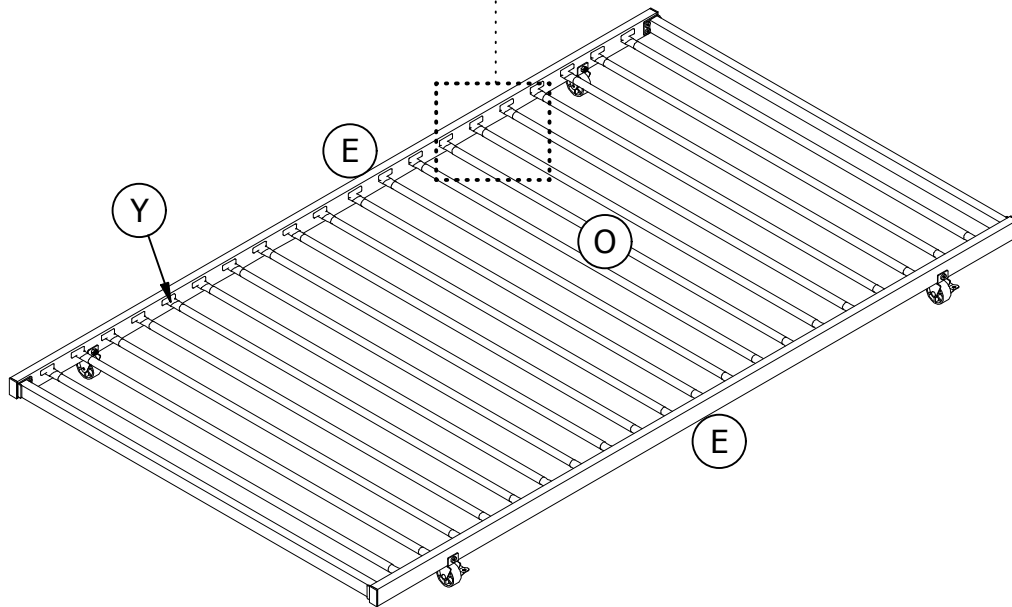

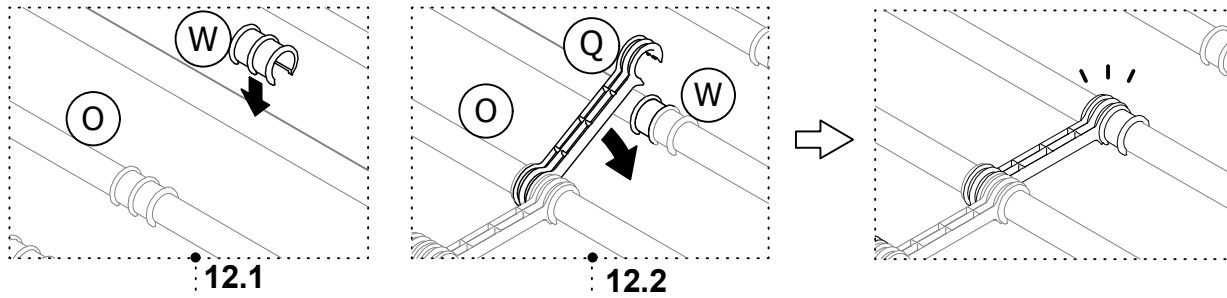

Step 12

12.1 Press Spacers **W** onto Slats **O** approximately in the middle of Slats **O** as illustrated.

12.2 Attach Spacers **Q** to Spacers **W** alternating left and right as illustrated.

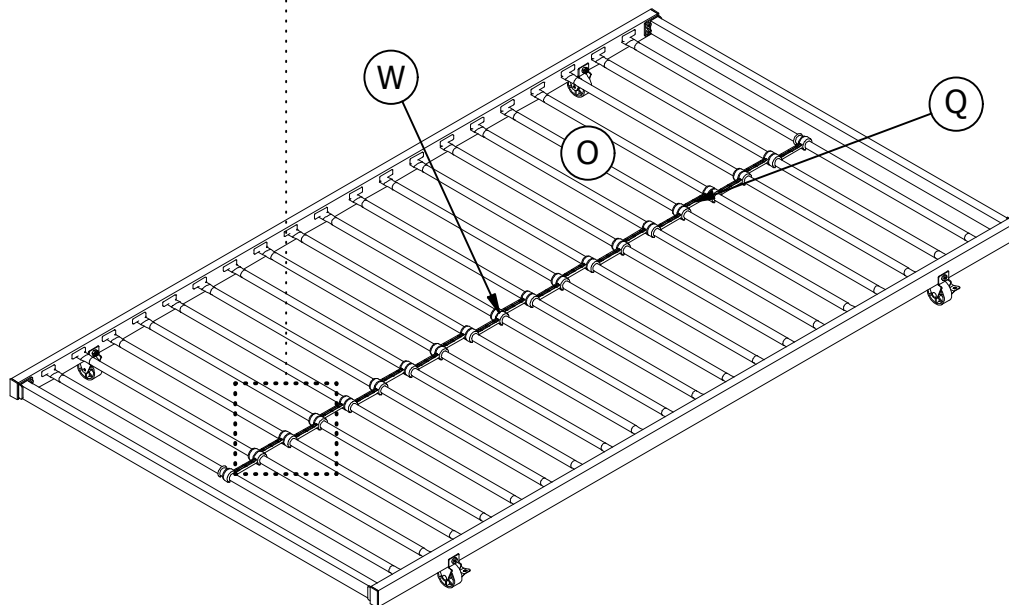

How to lock caster!

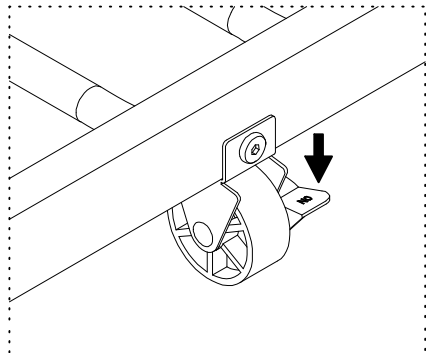

How to unlock caster!

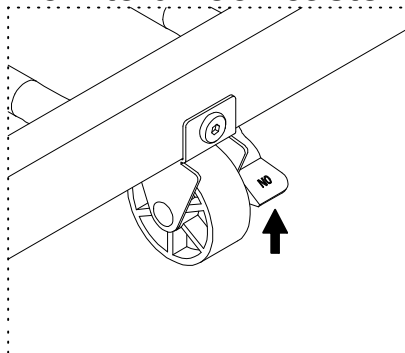

Helpful Hints

To use Trundle:

Pull out the trundle completely from underneath daybed. Once positioned, make sure casters are locked by pushing down the lever **"ON"** as illustrated **"How to lock caster!"**.

To store Trundle:

Unlock the casters by pulling up the lever **"ON"** as illustrated **"How to unlock caster!"** and push in the Trundle underneath the Daybed.

⚠ WARNINGS:

Keep casters in lock condition under normal use to prevent unintentional movement which may lead to instability and tipping.

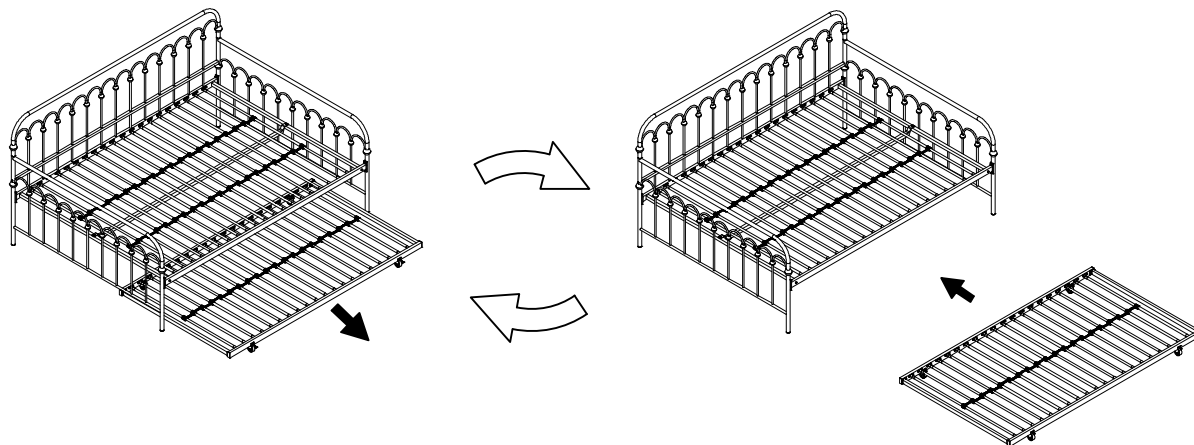

⚠ CAUTION: This unit is intended for use only with the products and/or maximum weights indicated. Use with other products and/or products heavier than the maximum weights indicated may result in instability or cause possible injury.

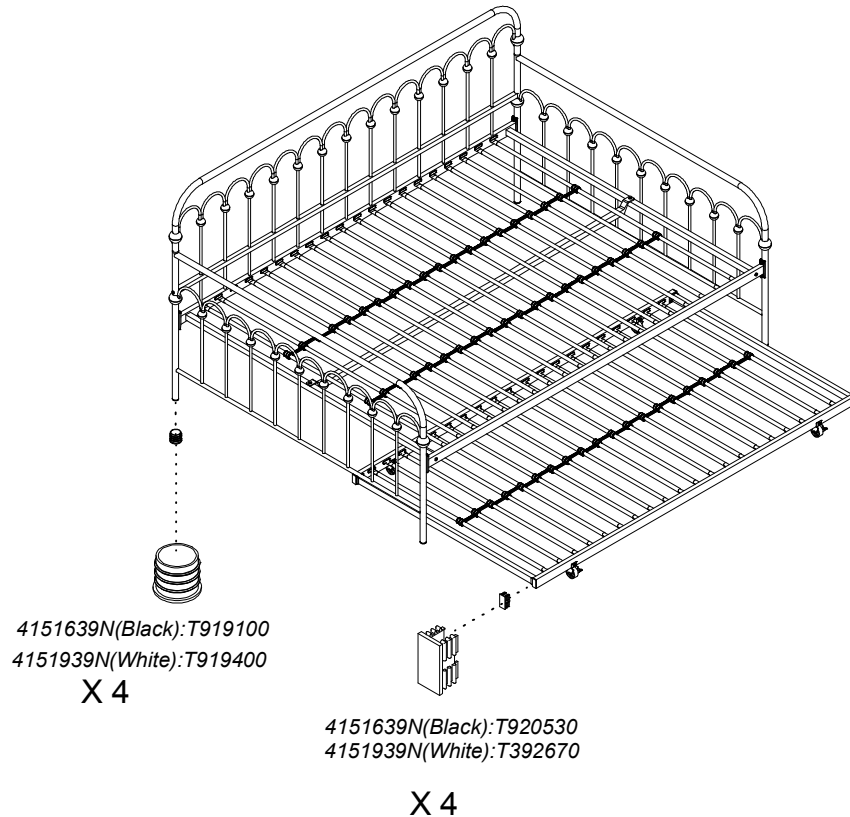

⚠ Weight Limit:
Daybed: 400 Lb / 181 kg
Trundle: 250 Lb / 113 kg

Helpful Hints

- Move your new furniture carefully, with two people lifting and carrying the unit to its new location.
- Your furniture can be disassembled and reassembled to move.
- Clean the product with a soft damp cloth. DO NOT use harsh chemicals or abrasive cleaners.
- Check bolts and nuts periodically and tighten if necessary.
- Some parts have been pre-assembled for this item. They are illustrated on this page and available for replacement.

⚠ WARNING

For safety reasons and to prevent injuries:

- This bed is not intended for use by children under 4 years old.
- Prohibit jumping and horseplay on this bed.
- Only use a mattress which is 74" - 75" long and 53" - 54" wide on bed.
- To optimize use of trundle, use a standard twin size mattress which is 74" - 75" long and 37½" - 3" wide, no thicker than 8".
- Do not use risers under this bed.

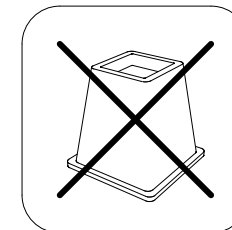

That's it ! You've finished assembling your **Metal Daybed With Trundle !**

4151639N(Negro),4151939N(Blanco)

Diván de metal con cama deslizable Matrimonial - Individual

Fecha de compra

Número de lote

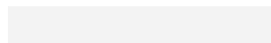
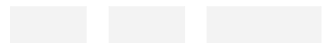

¡Gracias por tu compra DHP !

Información sobre la garantía

DHP garantiza que este producto está libre de defectos de material y de fabricación, comprometiéndose a corregirlos en caso de ser hallados. Esta garantía es válida por un año a partir de la fecha de compra original. Esta se limita únicamente a la reparación o reemplazo de partes defectuosas (no incluye la mano de obra).

Esta garantía no aplica para productos que hayan sido ensamblados incorrectamente, sujetos a algún tipo de maltrato o abuso, alteración o reparación. Responsabilidad por daños consecuentes está excluida en la medida de exclusión permitida por la ley. Esta garantía le brinda derechos legales e igualmente es posible que usted tenga otros derechos, los cuales pueden variar de Estado a Estado y de provincia a provincia.

Para obtener el servicio de garantía, debe presentar la factura original de su compra. Los componentes reparados o reemplazados están garantizados durante el periodo original de la garantía. Las partes defectuosas serán reparadas o reemplazadas sin cargo extra y sujetas a los términos y condiciones descritos anteriormente. Los términos y condiciones de la garantía limitada están sujetos a cambios sin previo aviso. Para conocer la política de garantía más reciente, visite www.dhpfurniture.com.

Precauciones

- Este producto está diseñado para uso doméstico y no para uso comercial.
- **ADVERTENCIA PARA NIÑOS PEQUEÑOS** - Este producto contiene componentes pequeños. Por favor asegúrese de que las piezas estén fuera del alcance de los niños.
- No utilice herramientas eléctricas para ensamblar su mueble. Este tipo de herramientas pueden rasgar o dañar las partes.

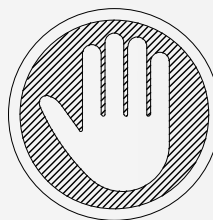

Preguntas, inquietudes, partes que faltan? **CONTACTE NUESTRO DEPARTAMENTO DE SERVICIO AL CLIENTE ANTES DE DEVOLVER EL PRODUCTO A LA TIENDA.**

Si le faltan piezas o las que se incluyen están dañadas, con mucho gusto le enviaremos sus piezas de reemplazo sin cargo extra.

Visite www.dhpfurniture.com/spa/replacement-parts , llame gratis al **1-800-267-1739** o chatea con nosotros al www.dhpfurniture.com



ESTE INSTRUCTIVO CONTIENE INFORMACION **IMPORTANTE** DE SEGURIDAD. POR FAVOR LEA Y GUARDE PARA SU REFERENCIA FUTURA.

Lea antes de comenzar a ensamblar

- Llame a nuestro número gratuito si necesita asistencia.
- Trabaje en un área espaciosa y cerca de donde su producto será utilizado, preferiblemente sobre una alfombra o utilice el cartón del empaque para proteger su piso y su producto.
- **El número de personas recomendadas para el montaje de este producto es: 2** (sin embargo es recomendable contar con ayuda adicional).
- **Tiempo estimado de ensamble es 1.5 Horas.**
- Asegúrese de que todas las partes están incluidas. La mayoría de las partes están etiquetadas o selladas en los bordes.
- Lea cada paso cuidadosamente. Es muy importante que cada paso de las instrucciones sea realizado en el orden correcto. Si estos pasos no se siguen en secuencia, pueden ocurrir dificultades durante el ensamblado.

¡Contáctenos !

Para solicitar ayuda con el ensamblaje, identificación de partes, información del producto o simplemente ordenar otras partes, diríjase a:

- Chatea con nosotros : www.dhpfurniture.com
- cs@dhpfurniture.com
- 1-800-267-1739
Lunes - Viernes / **9 am - 9 pm** (hora del este)
Sábado / **10 am - 6:30 pm** (hora del este)
Domingo / **11 am - 7 pm** (hora del este)
- DHP Servicios al Cliente
12345 Albert Hudon, Suite 100, Montreal, Quebec, Canada, H1G 3L1

Partes

Piezas de reemplazo, visite www.dhpfurniture.com/spa/replacement-parts



IMPORTANTE: La lista de números de piezas que aparece a continuación es exclusiva de su producto. Por favor, manténgalo a mano cuando solicite piezas de repuesto.

 Todo se incluye en 1 caja(s) grande(s)!



 Antes de deshacerse de las cajas de cartón, asegúrese de que estén vacías. También confirme que ha recibido todos los componentes necesarios para el ensamblaje al compararlos con la tabla de piezas indicadas en la sección en inglés.

NÚMERO DE PIEZAS			
ETIQUETAS DE PIEZAS	DESCRIPCIÓN	4151639N (Negro)	4151939N (Blanco)
E	Barandilla lateral	T949290	T951650
F1	Barandal de extremo	T1021980	T1022020
F2	Barandal de extremo	T1021990	T1022030
G	Barandal Trasero	T1022000	T1022040
H	Soporte final	T958740	T916440
J	Barandilla Lateral	T1022010	T1022050
M	Barandal de extremo	T910390	T926110
N	Rueda	T949310	T949280
N1	Rueda con bloqueo	T949300	T949270
O	Rueda	T919600	T930130
P	Tubo	T919610	T930230
Q	Separador para tubo	T919490	T919490
W	Separador para tubo	T919480	T919480
X	Soporte central	T953960	T953940
Y	Cubiertas de plástico	T392590	T392590

Paquete de componentes Canapé

4151639N(Negro)	 # de Paquete : T4151639N-00
4151939N(Blanco)	 # de Paquete : T4151939N-00

Paquete de componentes Rodar

4151639N(Negro)	 # de Paquete : T5585196-02
4151939N(Blanco)	 # de Paquete : T5585096-02

 **Nota:** Por favor no apriete completamente los pernos hasta que el ensamblaje sea completado, a menos de que se indique específicamente en cada paso de las instrucciones.

 Los tornillo(s), perno(s) que se utilizan en cada paso se muestran en tamaño real en la esquina inferior derecha de cada página.

Instrucciones

Paso 1

Para proteger el Barandal Trasero **G**, hemos agregado dos Barras adicionales. Remuevalas y descartelas antes de comenzar el ensamble.

Paso 2

Las instrucciones siguientes ilustrarán cómo ensamblar el Diván del Paso 2 al Paso 7. Utilice el paquete Daybed Hardware:

4151639N(Negro): **T4151639N-00**

4151939N (Blanco):**T4151939N-00**.

Una la **J** dentro de **F₁** & **F₂** con ⑤, ⑥ y ⑦.

Paso 3

Siga estrictamente la secuencia de ensamblaje del Paso 3 al Paso 4, o puede fallar el ensamblaje.

3.1 Insertar **C** dentro de **F₁** & **F₂**.

3.2 Una ⑤ dentro de **F₁** & **F₂** con ⑥ y ⑦.

Paso 4

Una **G** dentro de **F₁** & **F₂** con ①.

Una **F₁** & **F₂** dentro de **G** con ②.

Paso 5

5.1 Una **H** x 2 con **G** & **J** con ③.

5.2 Una **X** con **H** x 2 con ④ y ③.

Paso 6

Insertar **P** dentro **J** X 2, a continuación, Bloquee **P** en su lugar con **Y** como se muestra.

Paso 7

7.1 Presione **W** en la mitad de **P**.

7.2 Una **Q** con **W** alternando izquierda y derecha.

Paso 8

Las siguientes instrucciones desde el **PASO8** al **PASO12** ilustran como ensamblarla cama inferior. Por favor utilizar el paquete de componentes:

4151639N(Negro): **T5585196-02**

4151939N (Blanco):**T5585096-02**.

Una **N1** X 2 con **E** usando ① y ③.

Paso 9

Una **N** X 2 con **E** usando ① y ③.

Paso 10

Una **M** X 2 con **E** X 2 con ②.

Paso 11

Inserte **O** dentro de **E** X 2, a continuación, bloquee **O** en su lugar con **Y** como se muestra.

Paso 12

12.1 Presione **W** sobre **O** en el medio.

12.2 Presione **Q** sobre **W** alternando de derecha a izquierda.



Límites de peso:

Diván de metal : 400 Lb / 181 kg

Cama deslizable : 250 Lb / 113 kg

Consejos útiles

- Mueva sus muebles nuevos con cuidado, se requiere de dos personas para levantar y trasladar su producto a su nueva ubicación.
- Sus muebles se pueden desmontar y volver a ensamblar en caso de mudanza.
- Limpie el producto con un paño suave. NO utilice productos químicos o abrasivos de limpieza.
- Revise los tornillos y tuercas periódicamente y apriételos si es necesario.
- Algunas partes han sido pre-ensambladas en este producto. Se encuentran ilustradas en esta página y disponibles para reemplazo (sección en inglés).



PRECAUCIÓN

- Esta unidad está diseñada para ser utilizada únicamente con los productos y/o pesos máximos indicados. Su uso con otros productos y/o productos más pesados que los pesos máximos indicados puede provocar inestabilidad o causar lesiones.

Por razones de seguridad y para prevenir lesiones:

- Este producto no ha sido diseñado para ser utilizado por niños menores de 4 años.
- Prohibido saltar o jugar sobre la cama.
- Utilice únicamente un colchón que sea de 74" - 75" de largo y 53" - 54" de ancho.
- Para optimizar el uso de la cama inferior, use un colchón estándar de tamaño individual que sea de 74"-75" de largo y 37½"-38½" de ancho de máximo 8" de espesor.
- No utilice elevadores para cama con este producto.

4151639N(Noir),4151939N(Blanc)

Lit de jour en métal avec lit gigogne

Lit deux places - Lit une place

Date d'achat

Numero de lot

■■■■ ■■■■ ■■■■ ■■■■ ■■■■ ■■■■ ■■■■ ■■■■ ■■■■ ■■■■

Merci d'avoir acheté un produit DHP !

Informations sur la garantie

DHP garantit que ce produit est exempt de tout vice de matériaux et de fabrication et s'engage à remédier à un tel défaut. Cette garantie est valable un an à compter de la date d'achat initiale. Elle se limite uniquement à la réparation ou au remplacement des pièces défectueuses. La main-d'oeuvre nécessaire à l'assemblage n'est pas incluse.

Cette garantie ne s'applique pas aux produits qui ont été mal assemblés, qui ont été soumis à une utilisation abusive ou qui ont subi des modifications ou des réparations. Cette garantie vous confère des droits spécifiques légaux. Il se peut que vous bénéficiiez de droits additionnels car ceux-ci peuvent varier selon l'État ou la province.

Pour bénéficier du service de garantie, l'acheteur doit présenter la facture originale. Les composants réparés ou remplacés sont garantis jusqu'à la fin de la période de la garantie initiale uniquement. Les composants défectueux seront réparés ou remplacés sans frais, sous réserve des conditions décrites ci-dessus. Les termes et conditions de la garantie limitée sont susceptibles d'être modifiés sans préavis. Pour connaître la dernière politique de garantie, veuillez consulter le site www.dhpfurniture.com.

Précautions

- Ce produit est conçu pour un usage domestique et n'est pas destiné à des fins commerciales.
- **AVERTISSEMENT CONCERNANT LES JEUNES ENFANTS:** Ce produit contient des petits composants. S'il vous plaît assurez-vous qu'ils soient gardés loin d'eux.
- Ne pas utiliser d'outils électriques pour assembler votre mobilier. Ce type d'outils risque d'endommager les pièces.

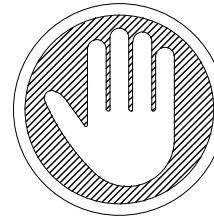

Des questions, des préoccupations ou des pièces manquantes? **CONTACTEZ NOTRE SERVICE À LA CLIENTÈLE AVANT DE RETOURNER LE PRODUIT AU DÉTAILLANT.**

Si des pièces sont manquantes ou endommagées, nous expédierons volontiers vos pièces de rechange gratuitement.

Visitez www.dhpfurniture.com/eng/replacement-parts, appelez sans frais au **1-800-267-1739** ou clavardez avec nous au www.dhpfurniture.com.



CE FEUILLET CONTIENT DES INFORMATIONS DE SÉCURITÉ **IMPORTANTES**. S'IL VOUS PLAÎT LIRE ET CONSERVER POUR RÉFÉRENCE ULTÉRIEURE.

Avant de commencer l'assemblage

- Si vous avez besoin d'aide, appelez notre service à la clientèle sans frais.
- Travaillez dans un endroit spacieux et près du lieu où l'unité sera utilisée, préférentiellement sur un tapis, ou sur un morceau de l'emballage, afin de protéger le plancher et le produit.
- **Nombre de personnes recommandées pour l'assemblage : 2** (cependant il est toujours préférable d'être assisté par une personne supplémentaire).
- **Temps estimé d'assemblage: 1.5 heures.**
- Assurez-vous d'avoir bien reçu toutes les pièces. La plupart de celles-ci sont étiquetées ou estampées sur leur côté non fini.
- Lire attentivement chaque étape avant de débiter. Il est très important que chaque étape de montage soit exécutée dans le bon ordre, sinon vous risquez d'éprouver de la difficulté à assembler votre meuble.

Contactez-nous!

Besoin d'aide pour assembler, identifier des pièces, vous informer sur le produit, ou pour commander des pièces? Contactez-nous :

- Clavardezavec nous: www.dhpfurniture.com
- cs@dhpfurniture.com
- 1-800-267-1739
Lundi - Vendredi / **9 am - 9 pm** (Heure de l'Est)
Samedi / **10 am - 6:30 pm** (Heure de l'Est)
Dimanche / **11 am - 7 pm** (Heure de l'Est)
- DHP Service à la Clientèle
12345 Albert Hudon, Suite 100, Montréal, Québec, Canada, H1G 3L1

Pièces

Pour des pièces de rechange, visitez www.dhpfurniture.com/fre/replacement-parts



IMPORTANT: La liste des références ci-dessous est propre à votre produit. Veuillez l'avoir sous la main lorsque vous appelez pour des pièces de rechange.

 **Tout dans 1 grande(s) boîte(s)!**



 **Avant de jeter les boîtes en carton, assurez-vous qu'elles soient vides. Vérifiez que vous avez reçu tous les composants nécessaires à l'assemblage en les comparant avec le tableau des pièces (illustrations disponibles dans la section en anglais).**

LISTE DES PIÈCES			
ÉTIQUETTE DES PIÈCES	DESCRIPTION	4151639N (Noir)	4151939N (Blanc)
E	Rail latpral	T1021980	T951650
F1	Fin garde-corps	T958740	T1022020
F2	Fin garde-corps	T1021990	T1022030
G	Garde Corps Arrière	T1022000	T1022040
H	Support d'extrémité	T958740	T916440
J	Rail Latpral	T1022010	T1022050
M	Entretoise de fin	T910390	T926110
N	Roulette	T949310	T949280
N1	Roulette de verrouillage	T949300	T949270
O	Lamelles	T919600	T930130
P	Lamelles	T919610	T930230
Q	Entretoise latte	T919490	T919490
W	Entretoise latte	T919480	T919480
X	Support central	T953960	T953940
Y	Bouchon de plastique	T392590	T392590

Quincaillerie Lit de repos

4151639N(Noir)	 # de Paquet : T4151639N-00
4151939N(Blanc)	 # de Paquet : T4151939N-00

Quincaillerie Lit gigogne

4151639N(Noir)	 # de Paquet : T5585196-02
4151939N(Blanc)	 # de Paquet : T5585096-02

 **Remarque:** Sauf indication contraire dans les instructions, ne pas resserrer complètement les vis et les boulons, jusqu'à ce que l'assemblage soit terminé.

 Les vis et boulons utilisés durant chaque étape sont illustrés en taille réelle au coin inférieur droit de la page.

Instructions

Étape 1

Afin de protéger le Garde Corps d'Arrière **G**, nous avons attaché deux Barres additionnelles. SVP les enlever et jeter avant de commencer l'assemblage.

Étape 2

Les instructions suivantes illustrent comment assembler la Méridienne de étape 2 à étape 7. s'il vous plaît utiliser le l'emballage coque: **T**.

4151639N (Noir): **T4151639N-00**

4151939N (Blanc): **T4151939N-00**.

Attacher **J** dans **F₁** & **F₂** avec **5**,

Étape 3

Veuillez suivre strictement la séquence d'assemblage de Étape 3 à Étape 4, sinon vous pourriez échouer à l'assemblage.

3.1 Insérer **G** dans **F₁** & **F₂**.

3.2 Attacher **5** dans **F₁** & **F₂** avec **6** et **7**.

Étape 4

Attacher **G** dans **F₁** & **F₂** avec **1**.

Attacher **F₁** & **F₂** dans **G** avec **2**.

Étape 5

5.1 Attacher **H** x 2 à **G** & **J** avec **3**.

5.2 Attacher **X** à **H** x 2 avec **4** et **8**.

Étape 6

Insérer **P** en **J** X 2, puis verrouiller **P** en place avec **Y**, tel qu'illustré.

Étape 7

7.1 Attacher **W** à **P**.

7.2 Presser **Q** sur **W** en alternant de gauche à droite.

Étape 8

Les instructions suivantes illustrent comment assembler lit inférieur de l'étape 8 à l'étape 12. S'il vous plaît utiliser le matériel pack:

4151639N (Noir): **T5585196-02**

4151939N (Blanc): **T5585096-02**.

Attacher **N₁** X 2 à **E** avec **1** et **5**.

Étape 9

Attacher **N** X 2 à **E** avec **1** et **5**.

Étape 10

Attacher **M** X 2 à **E** x 2 avec **2**.

Étape 11

Insérer **O** en **E** X 2, puis verrouiller **O** en place avec **Y**, tel qu'illustré.

Étape 12

12.1 Presser **W** dans **O** au milieu.

12.2 Presser **Q** sur **W**, en alternant de gauche à droite.



Limite de Poids:

Lit de jour en métal: 400 Lb / 181 kg

Lit gigogne: 250 Lb / 113 kg

Conseils utiles

- Déplacez votre nouveau mobilier avec soin, nous recommandons deux personnes pour soulever et transporter le mobilier vers son nouvel emplacement.
- Votre mobilier peut être démonté et réassemblé pour faciliter les déménagements.
- Pour le nettoyage, utilisez un linge doux et/ou humide. N'UTILISEZ PAS de produits abrasifs ou chimiques.
- Vérifiez les vis et écrous périodiquement et resserrez-les si nécessaire.
- Certaines pièces de ce produit ont été pré-assemblées. Elles sont illustrées sur cette page (section en anglais) et elles sont disponibles pour un remplacement.



AVERTISSEMENT

- Cette unité est destinée à être utilisée uniquement avec les produits et/ou les poids maximum indiqués. L'utilisation avec d'autres produits et/ou des produits plus lourds que les poids maximum indiqués peut entraîner une instabilité ou provoquer des blessures.

Pour des raisons de sécurité et pour prévenir les blessures:

- Ce lit n'est pas conçu pour être utilisé par des enfants de moins de 4 ans.
- Interdire le saut et le chahut sur le lit.
- Utilisez uniquement un matelas d'74"-75" de long par 53"-54" de large.
- Pour optimiser l'utilisation de votre lit inférieur, utilisez un matelas individuel qui soit de 74" - 75" de long, 37½" - 38½" de maximum 8" d'épaisseur.
- Ne pas utiliser rehausseur de lit sous ce produit.